

5G EVOLUTION – ON THE PATH TO 6G

Expanding the frontiers of wireless communications

White paper | Version 01.00 | Dr. Nishith D. Tripathi, Dr. Jeffrey H. Reed

ROHDE & SCHWARZ

Make ideas real



CONTENTS

- 1 5G Phase 1 and evolution toward 6G**3

- 2 Service expansion beyond Release 15**6
 - 2.1 5G LAN.....6
 - 2.2 Satellite access.....7
 - 2.3 Critical medical applications8
 - 2.4 5G V2X.....9
 - 2.5 UAVs or drones.....10
 - 2.6 Audio-visual production11
 - 2.7 Cyber-physical control applications.....12
 - 2.8 Positioning.....13
 - 2.9 Haptic services14
 - 2.10 Miscellaneous services15

- 3 NR enhancements beyond Release 15**.....16
 - 3.1 Integrated access and backhaul (IAB).....16
 - 3.2 NR unlicensed (NR-U)18
 - 3.3 URLLC enhancements19
 - 3.4 Industrial IoT (IIoT) enhancements.....20
 - 3.5 New frequency bands20
 - 3.6 Miscellaneous NR enhancements.....22

- 4 5G network architecture enhancements**.....24

- 5 Miscellaneous enhancements**26
 - 5.1 SEAL.....26
 - 5.2 5G SON27
 - 5.3 Security enhancements28

- 6 6G: A crystal ball perspective**29
 - 6.1 Predicting the 6G future29
 - 6.2 Key technologies as 6G enablers.....30
 - 6.2.1 Artificial intelligence30
 - 6.2.2 RF and optical technologies32
 - 6.2.3 Network technologies33
 - 6.3 Potential performance targets for 6G33
 - 6.4 Potential 6G services33

- 7 Summary**34

- 8 Literature**.....36

The Bluetooth® word mark and logos are registered trademarks owned by Bluetooth SIG, Inc. and any use of such marks by Rohde & Schwarz is under license.

1 5G PHASE 1 AND EVOLUTION TOWARD 6G

3GPP¹⁾ defined the fifth generation (5G) cellular technology in Release 15 to meet ITU's IMT-2020²⁾ performance requirements and to enable a variety of services associated with usage scenarios such as enhanced mobile broadband (eMBB), ultra-reliable low latency communications (URLLC) and massive machine type communications (mMTC). Example 5G performance requirements are 20 Gbps peak data rate, 1 ms radio network latency, 10 Mbps/m² area throughput and 1 million (low-rate) IoT devices per square kilometer. Key building blocks for 5G are the New Radio (NR) air interface, new radio and core network architectures, virtualization and automation technologies and new types of devices [1]. These building blocks enable 5G to offer targeted 5G services.

While Release 15 provides a solid framework for enhanced network performance and mass offering of amazing services, 3GPP is actively working on further enhancing the framework as shown in Fig. 1.1.

Fig. 1.1: Evolution path from 5G to 6G

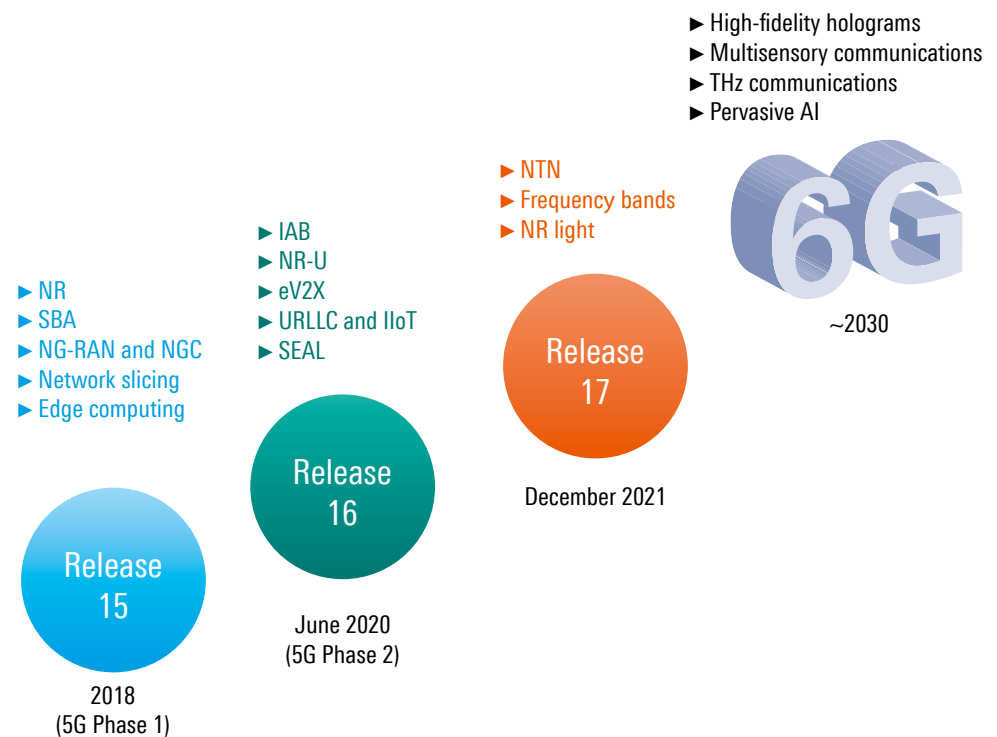

- **Release 15.** 3GPP defined 5G Phase 1 in Release 15 (R15). Example features of R15 include the New Radio (NR) air interface, new radio network architecture called next generation radio access network (NG-RAN), new core network architecture called next generation core (NGC) or 5G core (5GC), service based architecture (SBA), network slicing and edge computing.

¹⁾ 3GPP stands for Third Generation Partnership Project. 3GPP has previously defined specifications for third generation Universal Mobile Telecommunication System (UMTS) and fourth generation long term evolution (LTE).

²⁾ ITU is the International Telecommunication Union. A network is said to be a 5G network if it can meet International Mobile Telecommunications (IMT)-2020 performance requirements.

- ▶ **Release 16.** Planned features for Release 16 (R16), also called 5G Phase 2, include NR unlicensed (NR-U), integrated access and backhaul (IAB), enhanced vehicle-to-everything (eV2X), URLLC and industrial IoT (IIoT) enhancements and service enabler architecture layer (SEAL) for verticals.
- ▶ **Release 17.** Potential Release 17 (R17) features include non-terrestrial networks (NTN) (i.e. those using satellites), new frequency bands (e.g. 7 GHz to 24 GHz and > 53 GHz), enhancements to NR sidelink and NR light.
- ▶ **6G.** 5G Phase 1 deployments have started only recently, and releases beyond R15 will continue to tap into the tremendous potential of 5G. However, since a new generation of cellular technology typically appears every 10 years, 6G can be expected around 2030. 6G could offer high-fidelity holograms, multisensory communications (e.g. touch, taste and/or smell!), terahertz (THz) communications and pervasive artificial intelligence (AI).

Some features may initially be introduced in one release, but defined in an elaborated fashion in a future release. In this white paper, the 3GPP work in R16 and R17 is classified into the following categories: (i) service expansions, (ii) NR enhancements, (iii) network architecture enhancements and (iv) miscellaneous enhancements. Sections 2 to 5 contain an overview of the 3GPP work based on these categories. Our crystal ball view of 6G is given in section 6. Finally, section 7 summarizes the paper's key findings.

Before diving into R16 and beyond, here is a quick look at key features of 5G R15 [1].

- ▶ **NR air interface.** Like LTE, NR uses orthogonal frequency division multiplexing but makes it highly flexible. For example, variable subcarrier spacing, flexible radio frame structure including a self-contained slot, and carrier bandwidth parts are introduced. Both sub 7 GHz spectrum (called frequency range 1 or FR1) and millimeterwave spectrum (called frequency range 2 or FR2) are supported. The new high performance channel coding techniques of low density parity check coding and polar coding are defined. Spatial multiplexing techniques used in LTE, SU-MIMO and MU-MIMO³⁾ are enhanced in 5G. NR is a beamformed air interface with fewer beams at low frequency bands and more beams at high frequency bands. 5G supports hybrid beamforming where both digital beamforming (available in LTE) and analog beamforming are combined. Massive MIMO (mMIMO) in 5G enables enhanced combining of beamforming methods with spatial multiplexing.
- ▶ While NR provides a flexible air interface, it is advantageous in transitioning from 4G to 5G to use dynamic spectrum sharing (DSS) to dynamically allocate 4G and 5G subcarriers in the same channel. With DSS, mobile operators can simultaneously support 4G LTE, 5G NSA and 5G SA devices. DSS was introduced in R15, further refined in R16 and R17 and will probably continue to be refined in future releases, especially to improve the scheduling of resources between and within 4G and 5G subcarriers and across multiple cells. While the transition from one wireless generation to another in a specific band has been a painful experience in the past, it will be much easier with 5G thanks to DSS.

³⁾ SU-MIMO and MU-MIMO refer to single user multiple input multiple output and multi-user multiple input multiple output, respectively.

- ▶ **NG-RAN, NGC and SBA.** NG-RAN includes NR based 5G base stations called next generation node Bs or gNBs. A gNB can be decomposed or disaggregated into a central unit and a distributed unit. Such a gNB architecture reduces infrastructure and transport costs and provides scalability. While LTE uses a limited number of nodes in the evolved packet core (EPC), 5G defines more network functions (NF) that have fewer responsibilities. The overall 5G system is based on SBA, where NFs communicate with each other using service based interfaces. SBA facilitates the design and deployment of the 5G system using virtualization and automation technologies such as network functions virtualization (NFV), software defined networking (SDN), OpenStack and Orchestration.
- ▶ **Deployment options.** R15 fully defines two deployment options for the network architecture: non-standalone (NSA) NR and standalone (SA) NR. Non-standalone NR with the EPC uses the LTE eNB as the master node and makes use of a gNB's additional NR radio resources when possible. Standalone NR with the NGC does not rely on the LTE eNB at all and allows direct communications between the UE and the gNB.
- ▶ **Network slicing.** 3GPP introduces the concept of network slicing, where different logical networks are created using the same physical network to cater to different services and different customer requirements for a given service. Three standard slices for eMBB, URLLC and massive IoT are defined with support for numerous operator-defined network slices.
- ▶ **Edge computing.** 3GPP supports edge computing where the applications are located close to the UE. More specifically, 3GPP allows the selection of a gateway that is close to the gNB. Since user traffic passes through a local gateway instead of a remote gateway located deep inside the core network, both the end-to-end latency and transport requirements are reduced.

2 SERVICE EXPANSION BEYOND RELEASE 15

Although the work accomplished in R15 is useful for URLLC and mMTC usage scenarios, 3GPP focused more on the eMBB usage scenario in R15. Fig. 2.1 shows how 3GPP expands services beyond eMBB-related services in R16. Since 3GPP focuses on different verticals (i.e. industries), many of these services are related to verticals. Note that these services are not necessarily distinct from each other; there could be overlap among some services. These services are described in sections 2.1 to 2.10.

Fig. 2.1: New or enhanced services beyond 5G Phase 1

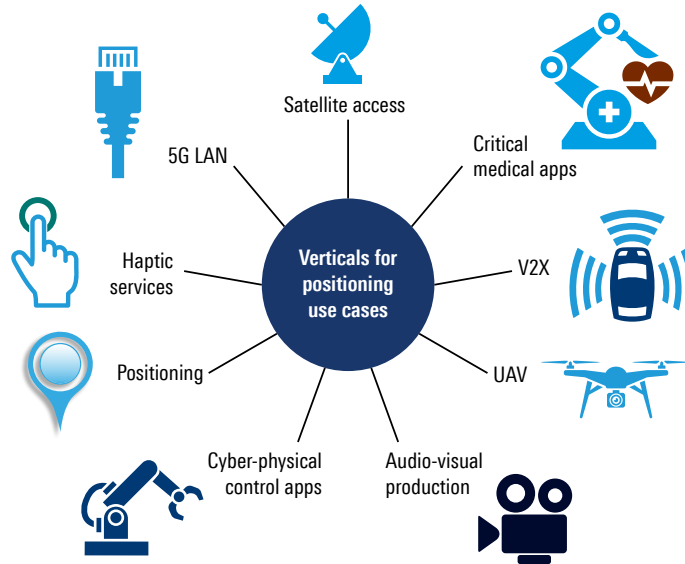

2.1 5G LAN

Fig. 2.2 shows the key concepts related to 5G local area network (LAN) services [TR22.821].

Fig. 2.2: 5G LAN

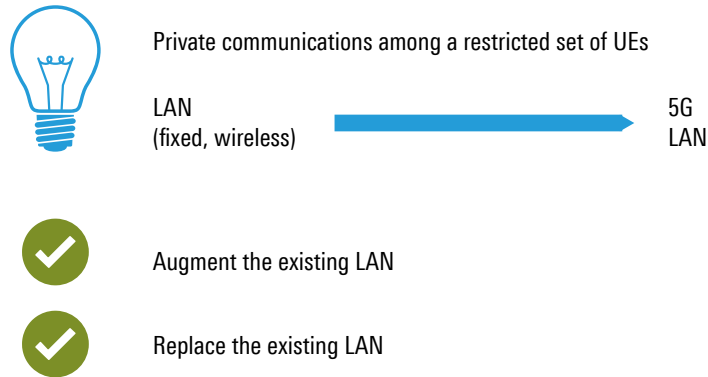

Scope

Residential, enterprise, industrial

Benefits

Performance, long-distance access, mobility, security

Similar to a fixed or wireless LAN, a 5G LAN provides private communications among a restricted set of UEs in a residential, enterprise or industrial setting. A 5G system can either augment or supplement an existing fixed or wireless LAN or completely replace such a LAN. A private virtual network (PVN) can be created using a 5G system. Compared to a traditional LAN, a 5G based PVN offers benefits such as superior performance, long-distance access, mobility support and enhanced security.

In the residential setting, different devices in a single home or different users in an apartment complex can obtain enhanced 5G QoS and maintain privacy and isolation of communications where needed. In the enterprise setting, 5G LAN helps connect computers, printers, scanners and servers, and facilitates access to private and secure settings across a large area or even across distant sites. In the industrial environment, controllers, actuators and sensors can be connected without the need for wires and with low latency communications. Reliable 5G wireless connectivity eliminates the need for Ethernet cables in a hazardous environment or in moving or rotating parts, and facilitates factory reconfiguration to increase productivity. In the case of IoT devices, two communications endpoints can even span countries, for instance a pipeline sensor in one country and a pipeline valve in another country.

When a network offers private communications services, such a network is referred to as a non-public network (NPN) or simply a private network. Only selected devices that are members of the NPN can obtain the network’s services. Devices that are not members of the NPN obtain services from the regular “public” network. Furthermore, the network resources (e.g. radio and core networks) are dedicated to the private entity that controls the NPN. The NPN may be fully independent of the regular public cellular network or may work in conjunction with the regular public cellular network.

2.2 Satellite access

5G aims to support satellite access in addition to terrestrial access. Fig. 2.3 summarizes three main use case categories where a satellite network using 5G can be used.

Fig. 2.3: Satellite access

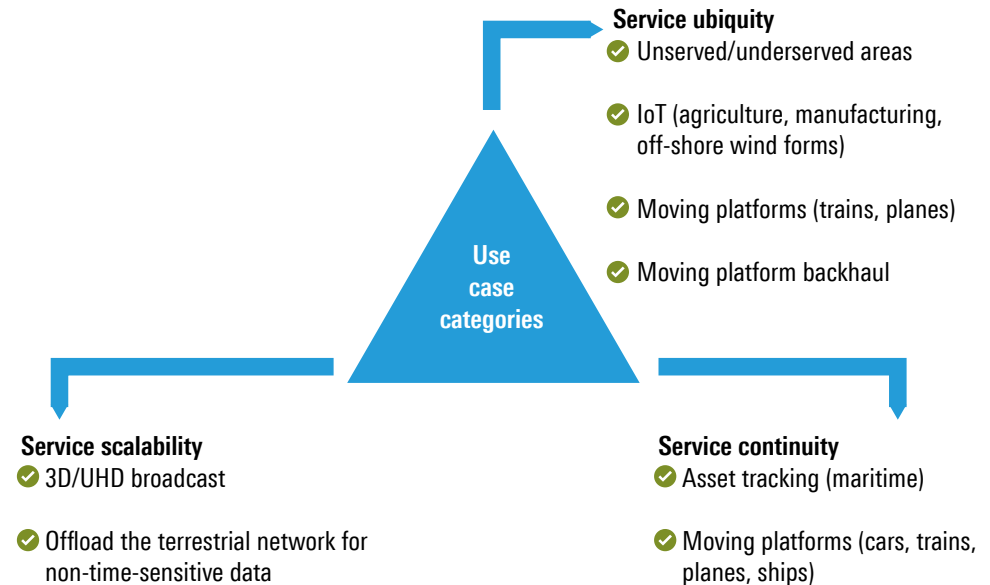

The three use case categories are service ubiquity, service continuity and service scalability. These categories are not mutually exclusive; a given use case may belong to more than one category.

- ▶ **Service ubiquity.** This category corresponds to the scenario where a terrestrial 5G network is not providing coverage but a satellite network is. For example, some rural or hard-to-reach areas may be unserved or underserved by a terrestrial network. Some IoT use cases such as smart agriculture, remote area manufacturing and offshore wind farms may not be economically viable for a terrestrial network but feasible for satellite access. If a terrestrial 5G base station (i.e. gNB) cannot connect to the 5GC using a typical fiber backhaul due to the lack of backhaul facilities, satellite access can come to the rescue. Since a satellite is helping with the implementation of backhaul, such a scenario is called moving platform backhaul.
- ▶ **Service continuity.** In some cases, the UE initiates communications with a terrestrial 5G network but moves out of the terrestrial system's coverage area. In such a case, service continuity can be ensured by using satellite access. Example use cases include asset tracking for IoT devices and people embarking on trains, planes and ships.
- ▶ **Service scalability.** Since a satellite covers a large geographic area (e.g. an area corresponding to hundreds or even thousands of terrestrial base stations), some broadcast content such as ultra high definition content or three-dimensional content can be efficiently and economically transmitted to many users simultaneously. The transmission of any non-time-sensitive data can also be offloaded from a terrestrial network to a satellite network.

2.3 Critical medical applications

5G can significantly influence healthcare by enhancing preventive care, reducing time-to-treatment and reducing overall costs [TR22.826].

In one category of critical medical applications, the patient and the medical specialists are collocated. This category can be further classified into "static – local" or "moving – local" depending upon whether the devices or people are moving while the care is being delivered. Since the care delivery for this category occurs inside a facility, indoor communications services are provided in a private 5G network.

In another category of critical medical applications, the patient and the medical specialists are located at different places. This category can be further classified into "static – remote" or "moving – remote" depending upon whether the devices or people are moving while the care is being delivered. Since the care delivery for this category occurs over a large area, communications services are delivered using 5G PLMNs.

- ▶ **Private 5G network use cases.** In an operating room (OR), a teleoperation system can be configured where a surgeon uses a console and a robotic system operates on the patient under the surgeon's guidance⁴⁾. URLLC and MEC are essential when the surgeon is working on a 3D model of the patient's body. The MEC application processes the patient measurements to bridge the robotic system and the surgeon's commands. In another use case of image-guided surgery, real-time video is wirelessly duplicated on multiple monitors. An operator controls the imaging equipment using a video monitor in one part of the OR, and the surgeon observes the video on a separate monitor. In augmented reality assisted surgery, a surgeon uses a head-mounted display (HMD) to perform the surgery. With the help of a MEC application, a combined

⁴⁾ In some types of robotic surgery, the robotic system can carry out more precise surgery through suitable instrumentation (e.g. within very small areas), and tremors in a surgeon's hand movements can be smoothed out by a suitable multi-access edge computing (MEC) application.

real-time video stream and reference medical image are displayed on the HMD to facilitate surgery.

- **5G PLMN use cases.** Distance is often a critical factor in emergency situations. 5G helps overcome such distance limitations when providing critical care to a patient. In one emergency care use case, an ambulance nurse can carry out an ultrasound examination at the incident location and perform suitable actions (e.g. applying pressure on a specific body part to prevent bleeding or damage) under the guidance of a remote medical specialist. The most suitable medical facility for the patient’s situation (e.g. a heart hospital) can be selected. A variety of sensors can be placed on the patient’s body and the emergency room (ER) can be prepared even before the patient has been transported to the ER. Remote surgery or telesurgery where a special surgeon does not need to be physically present is also possible, significantly expanding the reach of medical care to remote areas. In another use case, a connected ambulance can transmit important patient data to the ER from the instant the ambulance arrives at the incident scene to the point when the patient is brought to the operating table in an ER that has been prepared to meet the patient’s needs. In yet another use case, a patient recently discharged from the hospital has sensors on their body that track vital measurements and keep the appropriate medical facility informed. Prompt medical assistance is provided to the patient if the need arises.

2.4 5G V2X

While LTE can address some vehicle-to-anything (V2X) use cases, 5G V2X significantly expands the types of supportable use cases thanks to the high data rate, ultra-low latency and high reliability of 5G. Note that NR based V2X complements, and is not intended to replace, LTE based V2X. For example, basic safety messages can be sent using LTE based V2X, and scenarios that demand more stringent QoS requirements (e.g. latency, reliability and data rates) can benefit from NR based V2X. V2X, a subcategory of sidelink communications, supports not only vehicles but public safety with UE to UE communications. R17 will address the V2X issues that have been not been resolved in R15 and R16 and introduce study items to further extend the capabilities and applications of NR sidelink communications. R17 is expected to contribute enhancements in power savings, reliability and latency. Fig. 2.4 summarizes the use case groups targeted by 3GPP for 5G V2X [TR22.886].

Fig. 2.4: 5G V2X use case groups

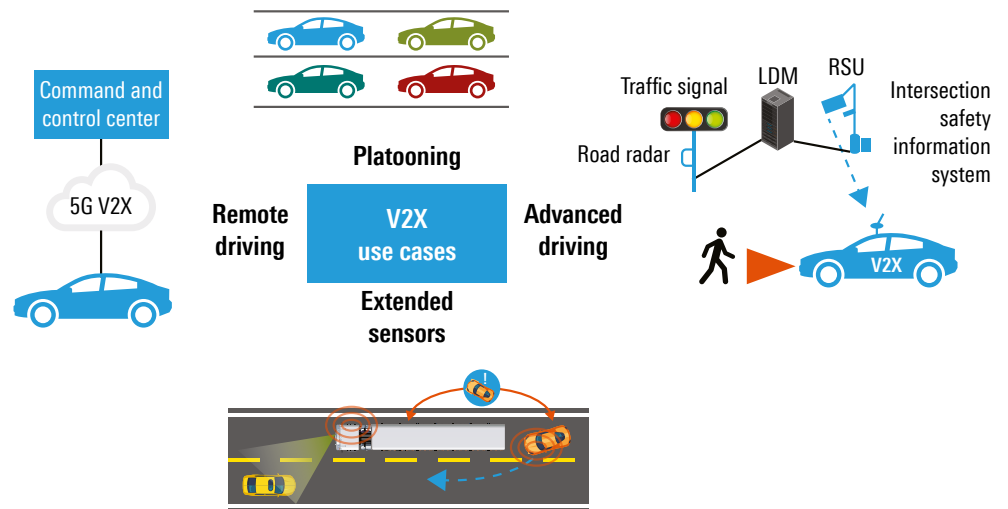

- ▶ **Platooning.** Platooning is operating a group of vehicles in a tightly-coupled manner. Such operation resembles a train with virtual cables between the vehicles. To maintain distance between the vehicles, the vehicles participating in platooning share their status information such as speed, heading and intention (e.g. braking or acceleration). Information about the platoon needs to be shared with vehicles that are not part of the platoon so as not to disturb the platoon. Platooning enhances safety by maintaining a safe distance while reducing the required distance between vehicles. Platooning reduces the overall fuel consumption and results in smoother traffic flow. The number of drivers needed to operate a given number of vehicles can also be reduced.
- ▶ **Advanced driving.** Vehicles can share a wide variety of information with each other to enhance safety and avoid or prevent accidents. For example, cooperative collision avoidance involves evaluating the probability of an accident and coordinated maneuvers using safety messages (cooperative awareness message or CAM and decentralized environmental notification message or DENM), sensor data, and commands for braking and accelerating. In the case of emergency trajectory alignment, when a vehicle learns about road obstacles through onboard sensors, it calculates a maneuver to avoid an accident and informs other nearby vehicles. These vehicles can then align their trajectories to cooperatively perform the emergency reaction. Similarly, at an intersection, a local dynamic map (LDM) server can monitor the road using a road radar and a traffic signal, generate LDM information and deliver that information to the vehicle via a roadside unit (RSU).
- ▶ **Extended sensors.** A vehicle can share its raw or processed sensor data with other vehicles and RSUs to create situational awareness. Such information sharing enables a vehicle to make tactical or maneuver decisions. For example, sharing of sensor data including high resolution videos can be used to detect objects that are not directly visible to the local sensors (e.g. behind other vehicles, on curves or behind the corners of buildings).
- ▶ **Remote driving.** In remote driving, a vehicle is controlled remotely by a human operator or a cloud server. For example, buses are driven on predetermined routes. A human operator can drive the buses with the help of suitable data such as video feeds containing views inside and outside the bus. A vehicle can be remotely driven to a suitable destination such as home or a medical facility if the human driver is unable to drive due to a personal situation (e.g. fatigue) or a health condition.

2.5 UAVs or drones

An unmanned aerial vehicle (UAV) or drone is a low-altitude (e.g. up to few hundred meters) flying vehicle that can be used to provide communications for a short time and/or in a limited geographic area. A UAV typically operates for up to 1 hour [TR 22.829]. After providing communications for a suitable time period, the UAV returns to its base for charging. A UAV may be controlled by a controller in the cloud, and delay-sensitive applications can be supported using multi-access edge computing (MEC). Artificial intelligence (AI) can also be used to control UAVs. Since traditional antennas in a cellular network use downtilting, support for UAVs requires adjusting existing antenna systems or separate antenna systems. Here are example use cases where UAVs can be used.

- ▶ **Live video broadcast.** A 360° spherical camera can be mounted on a UAV. This UAV can communicate with a gNB on the ground to send the 4k/8k video to a server in the cloud. People with AR glasses can then enjoy live video broadcast as if they were present at the venue.

- ▶ **Temporary radio access with internet connectivity.** In disaster or emergency situations, a UAV can act as a gNB (where it connects to a core network using wireless backhaul) or a relay (where it connects to a ground gNB that provides connectivity to the 5G core) to provide coverage quickly and cost-effectively.
- ▶ **Isolated radio access with private connectivity.** In some situations, such as construction in an isolated area, there is no traditional cellular radio access coverage or backhaul. A UAV can provide coverage more quickly and cost-effectively than ground based solutions. The UEs in a private group can communicate with one another via the UAV.
- ▶ **Swarm of UAVs for logistics.** A group of UAVs can be used in a coordinated fashion to deliver packages. Medicine and food supplies can be delivered in disaster situations even when the ground infrastructure has been damaged and become unusable.

2.6 Audio-visual production

A 5G network can facilitate audio-visual (AV) production services by providing flexibility, reducing costs and reducing communications setup times. Media could be produced within or outside the premises of a production company. Here are examples of AV production use cases where 3GPP can contribute [TR 22.827].

- ▶ **Studio based production.** Media could be produced in a studio using wireless microphones connected to a variety of audio sources, including singers, musical instruments and audio mixers. A 5G system can replace a costly and inflexible fixed infrastructure.
- ▶ **Newsgathering.** This use case represents unplanned ad-hoc production such as covering an important event. A 5G system can be set up quickly to produce relevant AV media and supply this media to the central facility for further processing and distribution.
- ▶ **Planned outside broadcasts.** An elaborate AV infrastructure with numerous cameras, microphones and mixers can be installed for a planned event (e.g. for elections or sporting events). A 5G system can facilitate media transmission from such event facilities to the central production base. Some media preprocessing could also be carried out locally. Sometimes a large coverage area is needed (e.g. a cycling race) and an airborne 5G NG-RAN can be deployed. Examples of audio production use cases include an onsite live audio presentation (with mixing of the presenter talk and audience questions) and audio streaming (with mixing of a singer's voice and audio streams of instruments, amplification of the mixed signal and distribution of combined audio streams on loudspeakers in the hall). Suitable devices can communicate with a 5G system to facilitate the production and distribution of media.
- ▶ **Live immersive media service.** Multiple cameras can be installed at various locations throughout the stadium and on players to create an immersive experience for the local and global audiences. An Olympic event is an example of an event that can be enjoyed through such an immersive experience.

2.7 Cyber-physical control applications

Cyber-physical control applications control the physical processes of cyber-physical systems, which consist of engineered and interacting networks of physical components and computational components. Cyber-physical control applications can be used in verticals such as industrial automation and energy automation. Here are example use cases related to these verticals [TR22.104] [TR22.832].

- ▶ **Factories of the future.** The manufacturing industry is experiencing the 4th industrial revolution or Industry 4.0, which aims to enhance flexibility, versatility, resource efficiency, cost efficiency, worker support and quality of industrial production and logistics [TR22.104]. A cyber-physical system is an enabling technology where 5G can be used. 5G can be applied to various aspects of automated factories such as factory automation, process automation, human-machine interfaces (HMI), production IT, logistics and warehousing, and monitoring and maintenance. Factory automation involves robotics and computer-aided manufacturing and is seeing the rising trends of modular and mobile production systems. Process automation involves the automation of processes that control the production and handling of substances such as chemicals, food and beverages. 5G can help establish communications among sensors, actuators and controllers. Various HMI devices such as panels associated with a production line and headsets exploiting AR/VR (e.g. step-by-step support from a remote expert for a specific task) will benefit from 5G connectivity. Logistics and warehousing involve controlling the flow and storage of substances using mechanisms such as automated guided vehicles (AGV) and forklifts. Monitoring and maintenance involve processing suitable sensor data to ensure long-term operation of the factory and to perform predictive maintenance.
- ▶ **Electric power distribution.** Smart grid is the emerging power distribution grid where insights are used to manage the distribution of power. In particular, the increasing focus on renewable energy (e.g. solar and wind energy), bidirectional electricity flows, and increasingly dynamic power systems require intelligent management of suitable resources. 5G can help connect a large number of local power generators, such as solar power units and wind turbines, to the smart grid. 5G based communications can facilitate fault detection and automatic restoration of electricity by using suitable measurement and control mechanisms.
- ▶ **Central power generation.** Centralized power generation involves converting chemical energy and other forms of energy into electric power. Large gas turbines, steam turbines, combined-cycle power plants and wind farms help generate electric power outputs of 100 MW or more. 5G can facilitate operations, monitoring and maintenance of such plants.

Time-sensitive networking (TSN) is an essential aspect of cyber-physical systems. Traditional TSN makes use of IEEE802.3 Ethernet based wired networks to ensure packet transport with bounded delays, latency variations and packet loss. 5G is expected to work with IEEE802.1 based TSN. Both device-to-device communications and UE-network communications may be used. Since Ethernet based communications is quite common in factories today, 5G-LAN service will play an important role in automated factories.

2.8 Positioning

While 4G LTE and 5G Phase 1 can certainly support location based services, use cases are being expanded significantly in R16 and beyond thanks to increased positioning accuracy. Fig. 2.5 summarizes example verticals that can benefit from positioning use cases [10].

Fig. 2.5: Verticals for positioning use cases

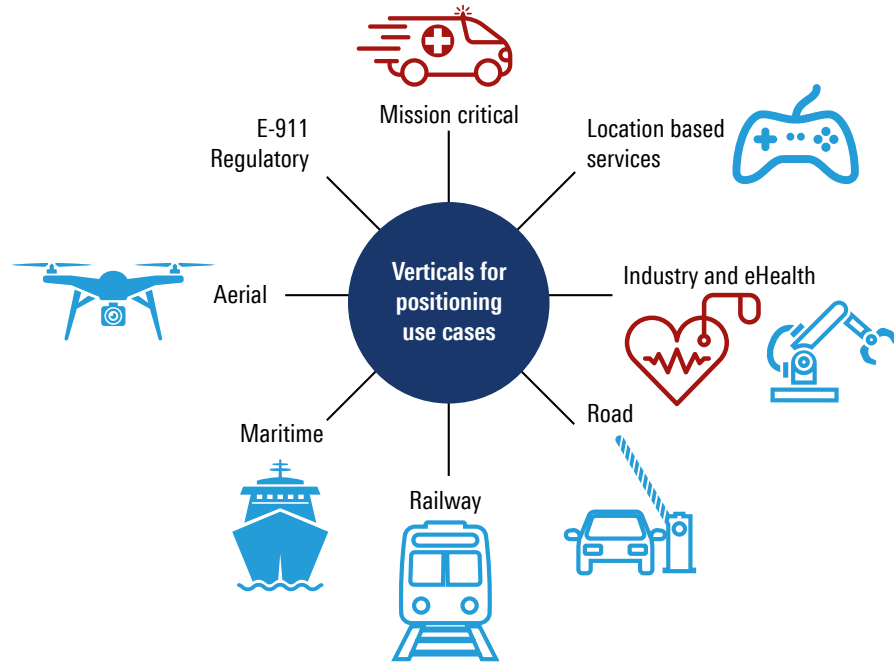

- ▶ **Mission critical.** In emergency situations, accurate positioning enables a user to get help from first responders by contacting a public safety answering point (PSAP), even in challenging environments such as urban canyon and deep indoors.
- ▶ **Location based services.** AR goggles and head-up displays (HUD) can make use of accurate positioning to superimpose contextual information on the user's real-world view to facilitate navigation, video recording and identification of targets. A shared bike service can benefit from accurate positioning where users can pick up and drop off bikes at suitable locations. Outdoor sports and leisure activities such as motorcycling, skiing and gaming can also make use of accurate positioning.
- ▶ **Industry and eHealth.** Accurate positioning is critical in many factory automation applications, including assembly and container management. In a hospital setting, people and medical equipment can be located accurately to facilitate prompt, high-quality care.
- ▶ **Road.** In the vehicular setting, 3D positioning facilitates traffic monitoring, management and control for smoother traffic flow to reduce commute times, save fuel and support emergency situations. Road user charging (RUC) levies a charge on a user based on the use of the road infrastructure.
- ▶ **Railway and maritime.** Asset tracking in railway and maritime applications increases transportation efficiency, reduces the possibility of lost or stolen containers, and facilitates logistics.

- ▶ **Aerial.** UAVs or drones can significantly benefit from accurate positioning for automatic landing as well as for personal or professional missions (e.g. delivery of medical supplies). Images and sensor data (e.g. infrared sensor data) can be merged with positioning data to facilitate UAV operations.
- ▶ **E-911 and regulatory.** The UE location supports E-911 calls and helps meet (and even exceed) regulatory requirements for lawful intercept.

3GPP aims to support a variety of positioning techniques in support of the use cases mentioned above [TR38.305]. The standard positioning methods supported for NG-RAN access include network assisted global navigation satellite system (GNSS) methods, observed time difference of arrival (OTDOA) positioning, enhanced cell ID methods, WLAN positioning, Bluetooth® positioning, terrestrial beacon system (TBS) positioning and sensor based methods (e.g. barometric pressure sensor and motion sensor). Hybrid positioning using multiple positioning methods is also supported. To support these methods, the UE and/or the network measures suitable signals (e.g. GNSS and LTE/NR signals) and estimates the position.

The GNSS based method makes use of UEs with GNSS radio receivers such as global positioning system (GPS) receivers. Different GNSSs such as GPS and Galileo can be used separately or in combination to determine the location of a UE. In the OTDOA positioning method, the UE measures timings of downlink signals received from multiple transmission points (TP) such as LTE/NR base stations. Enhanced cell ID (E-CID) positioning involves the use of the cell ID together with UE measurements and/or NG-RAN measurements. The barometric pressure sensor method uses barometric sensors to determine the vertical component of the position of the UE. In the WLAN positioning method, access point (AP) identifiers, WLAN measurements made by the UE, and databases are used to determine the UE location. The Bluetooth® positioning method involves the use of beacon identifiers and measurements of Bluetooth® beacons. In the TBS positioning method, the UE measures TBS signals. A TBS consists of a network of ground based transmitters that broadcast signals only for positioning purposes. Examples of TBS signals include metropolitan beacon system (MBS) signals and positioning reference signals (PRS). The motion sensor method makes use of various sensors such as accelerometers, gyros and magnetometers to determine the UE displacement.

2.9 Haptic services

Haptic is a sense perceived by touching an object. Haptic includes tactile sensing (touching surfaces) and kinesthetic sensing (sensing movement within the body) [TR22.987]. Recent advances in haptic feedback devices have been applied to different applications (e.g. haptic feedback from game controllers such as joysticks and steering wheels to simulate the tactile sense and/or kinesthetic sense for a player in a VR game). Because of its low latency, a 5G system could be used to deliver haptic feedback related to vibrations, temperature, texture or electronic stimulus. Examples of haptic senses include vibrotactile sense, shear sense, thermal sense and pneumatic sense.

A haptic service delivers haptic information from one party to another. Such a service could be initiated by the UE or the network and could be delivered asynchronously or synchronously. Here are some examples of haptic services.

- ▶ **Haptic emoticon delivery.** This service delivers the haptic information or haptic emoticon for enhanced communications experience by conveying emotions or feelings such as laughter and heartbeat. The haptic emoticon could be conveyed synchronously in real time together with voice and video or asynchronously in an SMS, MMS or IM.

- ▶ **Customized alerting.** This service replaces the default or customized alerting tones with a multimodal tone that combines customized haptic alerting with sound, video and other senses. When the calling party tries to establish a call to the called party, customized haptic alerting information along with typical information about the incoming call is sent to the called party's UE. The called party's UE generates suitable customized haptic alerting feedback for the user.
- ▶ **Call waiting alerting.** A subscriber may be notified of an incoming call through haptic feedback when engaged in an active call or holding a call. Such haptic feedback could be customized for different callers. The haptic feedback results in a more seamless communications experience by avoiding interruption.
- ▶ **Accident or health crisis.** An older adult may fall, triggering an alert to a suitable server and enabling prompt assistance. Even if a person is immobilized, help would be on the way due to automatic handling during the crisis.

2.10 Miscellaneous services

3GPP is evaluating NR based broadcast and multicast services (MBS), extended reality (XR) services, and multi-subscriber identity modules (SIM) as part of the R17 work/study items.

Broadcast and multicast services can significantly improve system efficiency and the user experience. The MBS over a 5G system (5GS) can be applied to use cases such as public safety, mission-critical services, V2X, transparent IPv4/IPv6 multicast delivery, IPTV, software delivery over wireless, group communications and IoT applications. The MBS over the 5GS would be supported for all NR RRC states: RRC_CONNECTED, RRC_INACTIVE and RRC_IDLE. A group scheduling mechanism would allow UEs to receive broadcast/multicast services. And a dynamic change between multicast and unicast would be supported. Mobility with service continuity would also be supported. In the initial implementation, the R15 physical layer would be reused. Any required changes to increase reliability (e.g. via uplink feedback) would also be studied. The resource allocation between unicast and multicast would be flexible.

XR is an umbrella term that encompasses augmented reality (AR), virtual reality (VR) and mixed reality (MR). Edge computing is expected to facilitate the realization of XR applications. NR in R15 is designed to be capable of supporting low latency, high reliability communications. In R17, 3GPP will evaluate various aspects of supporting XR, such as power consumption, capacity and mobility.

Since a user could have a personal subscription and a business subscription, a multi-universal subscriber identity module (MUSIM) can be quite beneficial. A USIM may be a physical SIM or an electronic SIM (eSIM). USIMs can belong to the same operator or different operators. Currently, MUSIM is supported in an implementation-specific manner. Standardized MUSIM support leads to enhanced performance due to more predictable UE behavior. For example, standardized MUSIM support reduces paging failures (e.g. a page sent in one network while the UE is in another network) and reduces the probability of missed packets (e.g. the user scheduled but is unable to receive traffic).

3 NR ENHANCEMENTS BEYOND RELEASE 15

3GPP created a high performance, ultra-flexible NR air interface in R15. The NR air interface is expected to serve as a strong foundation for subsequent releases. Fig. 3.1 lists potential NR enhancements⁵⁾ in R16 and beyond in support of the various new or enhanced services described in section 2.0. These NR features are explained in sections 3.1 to 3.6.

Fig. 3.1: NR enhancements beyond 5G Phase 1

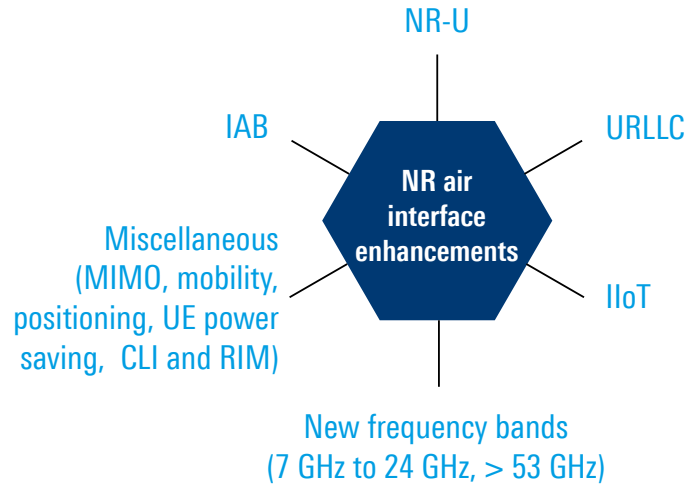

3.1 Integrated access and backhaul (IAB)

Integrated access and backhaul (IAB) means that spectrum can be shared between (i) wireless access to serve UEs and (ii) wireless backhaul to enable base station-core network connectivity. IAB can be used for outdoor small cell deployments, indoors or even mobile relays (e.g. on buses or trains) in the future. IAB can be viewed as a cost-effective deployment solution that simplifies radio-core connectivity and reduces the complexity of the associated fiber based transport network. IAB also reduces the overall time for deployment. Fig. 3.2, adapted from [TR38.874], illustrates example IAB deployments.

⁵⁾ 3GPP extensively studied an adventurous multiple access scheme called non-orthogonal multiple access (NOMA) but decided not to pursue it further. This means OFDMA (and optionally SC-FDMA) will continue to be the multiple access scheme of choice for the near-term future.

Fig. 3.2: Integrated access and backhaul

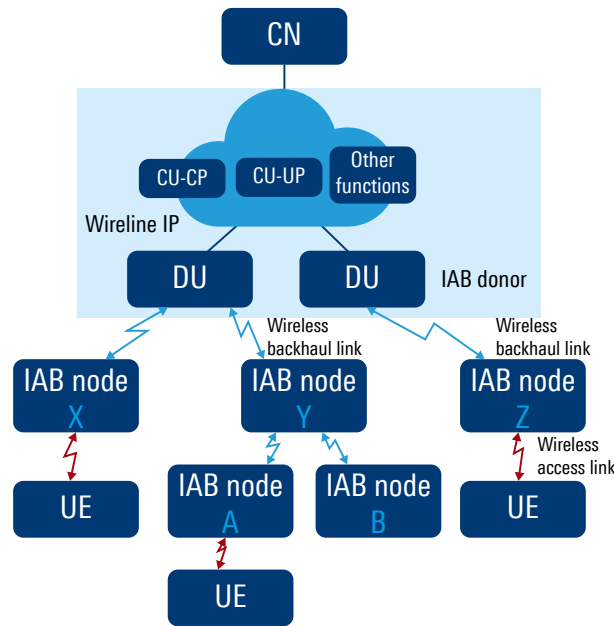

In Fig. 3.2, two base stations, IAB node X and IAB node Z use the spectrum to provide wireless access to their UEs and to communicate with the IAB donor base station that provides connectivity with the core network (CN). The IAB node does not have direct connectivity with the CN, while the IAB donor has CN connectivity. In addition, the IAB donor can provide wireless access to its own UEs. The 5G gNBs can be decomposed or disaggregated into a central unit (CU) and a distributed unit (DU) as specified in R15. IAB also supports a multi-hop link where the IAB node A base station connects to IAB donor through IAB node Y. Network synchronization among base stations is essential for effective IAB deployment. It is also important to effectively manage crosslink interference (CLI) between the access link and the backhaul link.

The IAB node contains a DU and a mobile termination (MT)⁶⁾. The IAB node uses DU to establish RLC channels toward UEs and toward MTs of downstream IAB nodes. The IAB node uses the MT to connect to an upstream IAB node or the IAB donor. The IAB donor contains a CU for its own DU as well as the DUs of all of its IAB nodes and a DU to support its own UEs and MTs of downstream IAB nodes.

Here are the potential characteristics or features of IAB.

- ▶ **In-band and out-of-band backhaul.** In-band backhauling implies that the access link and the backhaul link at least partially overlap in frequency. Out-of-band backhauling does not have such frequency overlap. Both sub 6 GHz spectrum and above 6 GHz spectrum are supported.
- ▶ **RAT and SA and NSA modes.** While NR based backhaul is the primary focus, LTE based backhaul may be supported. The IAB node may operate in standalone NR mode or non-standalone NR mode.
- ▶ **Topology adaptation.** This feature autonomously reconfigures the backhaul network to mitigate the effects of blockage and loading variations. Blockage may occur due to vehicles, foliage or new construction. Loading variations and subsequent node congestion could occur due to traffic variations.

⁶⁾ Mobile termination (MT) terminates the radio interface layers of the backhaul Uu interface toward the IAB donor or the IAB node.

3.2 NR unlicensed (NR-U)

LTE based licensed assisted access (LAA) uses licensed spectrum for an anchor carrier frequency and unlicensed spectrum carriers on an opportunistic basis to improve throughput. LAA uses carrier aggregation across licensed spectrum and unlicensed spectrum to transmit data in parallel. Since unlicensed spectrum may have a large amount of unlicensed spectrum available at an instant, LAA tries to make use of such spectrum when interference is below a threshold. R16 reuses the concept of LAA with NR based air interface and supports additional deployment scenarios using unlicensed spectrum [TR38.889]. Potential deployment scenarios for NR-U are summarized below.

Scenario A: CA between licensed spectrum NR (primary cell or PCell⁷⁾) and unlicensed spectrum NR (secondary cell or SCell). An NR SCell in the unlicensed spectrum may have both DL and UL, or DL only. A gNB serving a small cell can easily implement such CA.

Scenario B: Dual connectivity between licensed spectrum LTE (PCell) and unlicensed spectrum NR (primary SCell or PSCell). Dual connectivity implies two independent schedulers at two base stations, which are an LTE eNB and an NR gNB in this scenario.

Scenario C: Standalone NR in unlicensed spectrum. In this scenario, there is no need for the anchor carrier frequency to be in the licensed spectrum. NR is used solely in the unlicensed spectrum. Such a scenario is like MulteFire, where LTE is used in the unlicensed spectrum with no dependence whatsoever on the licensed spectrum.

Scenario D: DL in unlicensed spectrum and UL in licensed spectrum. An NR based gNB uses unlicensed spectrum for the downlink, but licensed spectrum for the uplink for a given UE. This scenario targets DL-heavy traffic situations such as video streaming.

Scenario E: Dual connectivity between licensed spectrum NR (PCell) and unlicensed spectrum NR (PSCell). In this scenario, one gNB uses licensed spectrum to provide PCell, while the second gNB uses unlicensed spectrum.

The initial focus of NR-U is on unlicensed spectrum below about 7 GHz, with support for higher frequency unlicensed spectrum expected in future releases. Example frequency bands being targeted for NR-U include the widely used 5 GHz band (e.g. 5.150 GHz to 5.925 GHz) and the new 6 GHz band (e.g. 5.925 GHz to 7.125 GHz in the USA and 5.925 GHz to 6.425 GHz in Europe).

⁷⁾ Primary cell or PCell provides an RRC signaling connection (and quite often radio resources for user traffic) to the UE on a specific carrier frequency. Secondary cell or SCell typically provides additional radio resources for user traffic on a separate carrier frequency.

3.3 URLLC enhancements

R15 NR defines the frame structure that can be used as the baseline to support URLLC applications. However, for enhanced AR/VR for the entertainment industry, factory automation, transport industry (e.g. ITS use cases and remote driving use case) and electrical power distribution, additional NR enhancements are needed to increase reliability (e.g. from 10^{-5} to 10^{-6} error rate), to reduce latency (e.g. on the order of 0.5 ms to 1 ms) and to ensure tight synchronization (e.g. on the order of few microseconds). Fig. 3.3 summarizes target enhancements to support more URLLC use cases.

Fig. 3.3: NR enhancements for URLLC

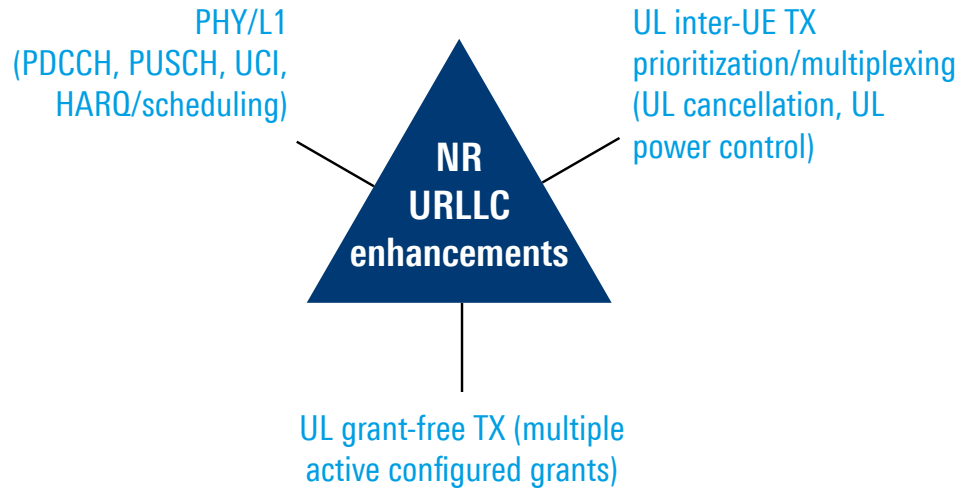

- ▶ **PHY/L1 and MAC enhancements.** Enhancements are being targeted for several physical layer aspects such as PDCCH, PUSCH, UCI and HARQ/scheduling. PDCCHs can use compact DCI for faster processing and configurable field sizes. More PDCCHs can be monitored within a slot. PUSCH can be repeated in a slot or in consecutive slots. UCI can support more than one PUCCH for HARQ-ACK transmission, and at least two HARQ-ACK codebooks can be supported to cater to different services for a given UE. Out-of-order HARQ-ACK is supported, where the HARQ-ACK for the second PDSCH can be sent before the HARQ-ACK for the first PDSCH. A second PUSCH can be scheduled before the first PUSCH is over.
- ▶ **UL inter-UE transmission prioritization/multiplexing.** Example enhancements include UL cancellation and enhanced UL power control. The UE may be sent an indication about UL cancellation. If transmission has already started, the UE cancels the UL transmission. Otherwise, the UE does not start the transmission. Potential power control enhancements include dynamic power boost for URLLC, enhanced TPC parameters such as larger TPC range and finer granularity of transmit power adjustments.
- ▶ **Enhanced UL grant-free transmissions.** R15 supports configured grants to facilitate grant-free transmissions in the uplink. Beyond R15, there can be multiple simultaneously active configured Type 1 and Type 2 grants. A Type 1 grant means that RRC signaling is used for configuration as well as activation and deactivation of the grant. In contrast, a Type 2 grant means that configuration is provided by RRC signaling but activation and deactivation are carried out using PDCCH signaling.

3.4 Industrial IoT (IIoT) enhancements

While industrial IoT would undoubtedly benefit from the URLLC enhancements summarized in section 3.3, industrial IoT has specific requirements that need additional enhancements. For example, wireless Ethernet and time-sensitive networking (TSN) need to be supported. The following are IIoT-specific enhancements being targeted by 3GPP [TR38.825].

- ▶ **PDCP duplication.** R15 supports PDCP duplication for increased reliability. Beyond R15, multiple RLC entities (e.g. up to a limit such as 4) can be configured to allow multiple PDCP copies of data. The actual subset of RLC entities can be controlled dynamically (e.g. using a MAC control element). Since duplication consumes more resources, mechanisms to increase resource utilization efficiency become important when PDCP duplication is active. Selective duplication, selective discarding and activation/deactivation of PDP duplication enhancements are examples of such mechanisms.
- ▶ **Intra-UE prioritization.** To cater to higher priority IIoT traffic, suitable prioritization methods can be helpful. Examples include higher priority for a later dynamic grant compared to an earlier dynamic grant, higher priority for a configured grant compared to a dynamic grant, and resolution of the transmission conflict between the scheduling request for higher priority traffic and lower priority user traffic.
- ▶ **TSN reference timing.** To facilitate precise timing synchronization, reference times can be delivered from the gNB to the UE using broadcast and/or unicast RRC signaling. The goal for the timing granularity is at least 50 ns.
- ▶ **Scheduling.** To facilitate QoS-aware scheduling of TSN traffic, information about TSN traffic patterns such as message periodicity, message size, DL message arrival time at gNB and UL message arrival at the UE could be provisioned from the core network to the RAN. Multiple simultaneously active configured grants (CG) and semi-persistent scheduling (SPS) configurations for a given BWP of a UE would be supported. Additionally, support for shorter SPS periodicities than the existing ones would further reduce latency.
- ▶ **Wireless Ethernet.** Ethernet header compression would be supported to reduce overhead.

3.5 New frequency bands

In R15, 3GPP initially defined FR1 to cover 450 MHz to 6 GHz and FR2 to cover 24.250 GHz to 52.6 GHz. FR1 was later extended in R15 to cover 410 MHz to 7.125 GHz to include the 6 GHz unlicensed spectrum in the higher frequencies and any available spectrum around 400 MHz (e.g. T-GSM 410 or GSM trunking system from about 410 MHz to about 430 MHz). 3GPP is exploring further frequency band increases in the 7.125 GHz to 24.250 GHz range and above 52.6 GHz. The 7.125 GHz to 24.250 GHz frequency range may be divided into multiple frequency bands such as 7.125 GHz to about 10-13 GHz, 10-13 GHz to 16-18 GHz, and 16-18 GHz to 24.250 GHz. The existing FR1/FR2 may be extended or new FRs may be defined. In higher frequencies such as 52.6 GHz to 71 GHz, new OFDM numerologies may be defined.

Higher frequencies such as those greater than 52.6 GHz are characterized by the challenges of higher propagation path loss, higher phase noise, larger insertion losses in the RF frontend, more low noise amplifier (LNA) noise, more analog-to-digital converter (ADC) noise, and lower power amplifier efficiency compared to lower frequencies⁸⁾.

⁸⁾ 3GPP is studying several waveforms that are different than the currently used OFDM waveforms. These new waveforms may be better suited for higher frequencies.

However, these higher frequencies offer the benefit of large channel bandwidths and subsequently high throughput, low latency and high capacity. Fig. 3.4 depicts example use cases that could be supported using the spectrum above 52.6 GHz.

Fig. 3.4: Example use cases for the spectrum above 52.6 GHz

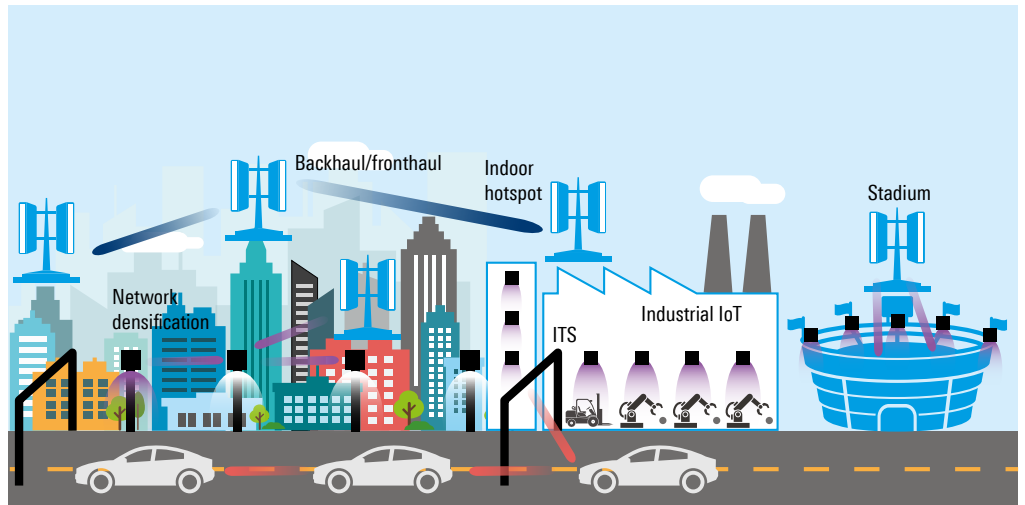

Network densification. With the ultra high definition displays, AR/VR apps and mobile 3D projects, data traffic demand is expected to soar even further. Network densification is an effective mechanism to meet the ever-increasing data traffic demand. Higher frequency bands are suitable for the small cell deployments needed for network densification.

Backhaul and fronthaul. The availability of large bandwidth at higher frequencies makes these frequencies suitable for wireless backhaul. Decomposition or disaggregation of the gNB requires two logical parts of the gNB to communicate with each other. In one possible scenario, baseband and RF portions can communicate with each other using wireless fronthaul.

Indoor hotspots and stadiums. Heavy indoor or outdoor data traffic demand can be met by deploying large bandwidth, high frequency hotspots. And higher frequency reuse is possible due to small cells.

ITS. Vehicle-to-vehicle and vehicle-to-infrastructure communications in an intelligent transport system (ITS) is typically carried out over short distances. Large bandwidths enable wireless transfer of high definition videos and sensor data between the vehicles and of high definition maps from the infrastructure to the vehicles.

Industrial IoT. Factory automation can benefit from private 5G networks using high frequency spectrum in a local area with significant frequency reuse thanks to small cells. Larger subcarrier spacing can reduce latency, and wider channel bandwidths can achieve high data rates and high reliability.

3.6 Miscellaneous NR enhancements

- ▶ **UE power saving.** The UE battery life is an essential aspect of the user's overall service experience. Several mechanisms can be employed to reduce the UE's battery consumption in connected mode and non-connected mode [TR38.840]. For example, monitoring of control channels such as PDCCHs, RRM measurements, suitable transitions between the connected mode and power-efficient mode, adaptation of MIMO layers, BWP switching, efficient paging, cross-slot scheduling and flexible DRX cycles can be used to influence the UE's power consumption. The UE may provide assistance information such as mobility history and power preferences, which can be used by the network to minimize power consumption while avoiding a significant adverse impact on the service performance (e.g. latency).
- ▶ **MIMO enhancements.** R15 provides benefits such as enhanced codebooks, reference signal design flexibility and support for advanced antenna techniques for both sub 6 GHz and above 6 GHz deployments. Beyond R15, MIMO can be further enhanced to increase robustness, reduce overhead and/or reduce latency. For example, MU-MIMO can be enhanced by supporting more than two layers in CSI Type II feedback, reducing PAPR for reference signals, control signaling for non-coherent joint transmission, more antenna panels, enhanced beam failure recovery and enhanced DL/UL beam selection [24].
- ▶ **Mobility enhancements.** R15 uses LTE-like handover, where the network controls mobility based on measurements provided by the UE. However, meeting the 0 ms interruption time target can be a challenge in the current break-before-make approach when there is a change in the gNB or secondary cell group (SCG). In particular, the beamformed NR interface introduces complexities. Example mobility enhancements include random access channel (RACH)-less handover, fast handover failure recovery, and handover or secondary cell group (SCG) change with simultaneous connectivity with source cell and target cell. Various R15-supported scenarios such as intra-frequency handover, inter-frequency handover, inter-CU handover, intra-CU/inter-DU handover and intra-DU handover would be supported in conjunction with mobility enhancements.
- ▶ **NR positioning.** NR based positioning techniques aim to achieve < 3 m accuracy in horizontal and vertical positioning for indoor deployments and < 10 m accuracy in horizontal positioning and < 3 m accuracy in vertical positioning for outdoor deployments [TR38.855]. New positioning reference signals would be used. Example positioning techniques include DL time difference of arrival (DL-TDOA), DL angle of departure (DL-AoD), UL time difference of arrival (UL-TDOA), UL angle of arrival (UL-AoA), round trip time (RTT) and enhanced cell identity (E-CID). The UE and the gNB make measurements in support of these techniques. The UE observes reference signals from serving and neighboring gNBs and makes DL measurements such as reference signal time difference (RSTD), reference signal received power (RSRP) and UE RX-TX time difference. In the radio network, the following measurements are made at serving and neighboring gNBs: relative time of arrival (RTOA), angle of arrival (AoA) (including azimuth and zenith angles), RSRP and gNB RX-TX time difference.
- ▶ **CLI and RIM.** In a TDD system, when two gNBs use the same slot format on a given carrier frequency, co-channel interference and adjacent channel interference are minimized. However, if dynamic TDD is implemented and if gNBs independently choose their slot formats, co-channel crosslink interference (CLI) occurs. 3GPP's work includes the definition of reference signals and measurements to quantify CLI, investigation of CLI mitigation mechanisms and identification of coexistence requirements [TR38.828]. Another interference of interest is remote interference, where a remote gNB signal from a macro cell undergoes tropospheric bending and causes interference at another macro gNB. 3GPP is exploring remote interference

management (RIM) mechanisms (e.g. a reference signal to facilitate detection of remote interference and adjustment of the guard period) to mitigate such remote interference.

- ▶ **NR light.** NR light aims to reduce the complexity and the cost of certain types of devices relative to typical R15 based devices. Smartphones and URLLC based devices are high-end devices with stringent data rate, latency and/or reliability performance requirements. Many IoT devices are low-end devices (e.g. smart water meters and smart sensors) with relaxed latency and data rate requirements. However, devices such as smart wearables are somewhere between these two extremes; they have mid-range cost and performance requirements. NR light aims to reduce the complexity of such mid-range devices.
- ▶ **NR coverage enhancement.** Coverage influences service quality and expenditures such as CAPEX and OPEX. Since NR is often intended for frequencies higher than those typically used for LTE, this study item aims to carry out an evaluation of NR coverage performance. Both FR1 and FR2 would be considered. And potential coverage enhancement solutions would be studied, with voice over internet protocol (VoIP) and eMBB as target services. Example coverage enhancements include time domain solutions, frequency domain solutions and demodulation reference signal (DM-RS) enhancements (including DM-RS-less transmissions).
- ▶ **NR small data transmissions.** UEs with infrequent periodic or aperiodic traffic may be kept in the RRC_INACTIVE state. 3GPP is working on support for small data transmissions in the RRC_INACTIVE state. Such support eliminates transitions between RRC_CONNECTED and RRC_INACTIVE states, saving power, reducing the amount of signaling and increasing network performance and efficiency. Examples of applications that can benefit from this feature include smartphone applications (e.g. instant messaging, push notifications, and keep-alive traffic from applications such as email) and non-smartphone applications (e.g. wearable device traffic involving positioning, sensor data and smart meter traffic). This feature benefits from several building blocks defined in R15 and R16, such as 2-step RACH, 4-step RACH and configured grant type 1. Small data transmissions may accompany certain messages during the RACH procedure. More flexible payload sizes may be defined.
- ▶ **NR QoE management and optimizations.** NR is designed to be flexible so that services with diverse performance requirements can be supported. R17 would study quality of experience (QoE) aspects such as the collection of suitable experience parameters and adaptive QoE management schemes to enable intelligent network optimization to meet user experience requirements for diverse services. For example, NR RAN may need to collect user key performance indicators (KPI) such as an end-to-end reliability statistic indicator. QoE parameters can be UE-specific and service-related and more elaborate than traditional metrics such as throughput, capacity and coverage. QoE metrics can be used to evaluate the network quality, and solutions could be evaluated from the user experience and service experience perspectives. A generic framework for triggering, configuring and reporting QoE measurements would be defined. The potential impact of QoE management on network interfaces would be studied.

4 5G NETWORK ARCHITECTURE ENHANCEMENTS

While the network architecture defined in R15 is quite flexible, 3GPP is making enhancements to expand the utility of the network. Below are some examples of network enhancements related to V2X, network automation, Common API Framework (CAPIF) and IP Multimedia Subsystem (IMS).

- ▶ **V2X enhancements.** The 5G system (5GS) is undergoing several enhancements to support NR based V2X. For example, NR based PC5 and Uu interfaces are supported [TS23.287]. The UE provides V2X capabilities to the 5GC and receives V2X configuration parameters (e.g. destination Layer 2 IDs for device-to-device communications) over the N1 interface. The policy control function (PCF) provides V2X policy parameters to the UE. A V2X application server exchanges unicast V2X data with the UE in the downlink and the uplink. The unified data repository (UDR) stores V2X service parameters, while unified data management (UDM) manages V2X subscriptions.
- ▶ **Network automation.** A step toward network automation was taken when the network data analytics function (NWDAF) was defined in R15. 3GPP is working on enhanced network automation by enhancing NWDAF interactions with other network functions (NF) and with operations, administration and management (OAM) [15]. In particular, NFs and OAM provide raw data to NWDAF, and NWDAF calculates network analytics. These analytics can be used by NFs and OAM to modify parameters that influence network operations (e.g. load balancing via cell selection and handover parameters). While NWDAF would typically be a centralized entity, its local instance may exist in a given geographic area in support of edge computing. Furthermore, NFs may also calculate network analytics and convey those to NWDAF. Artificial intelligence (AI) techniques can be applied to NWDAF or any suitable NF. 3GPP would continue to define NWDAF inputs and outputs for various functions. AI techniques would be implementation-specific with suitable measurement support from 3GPP NFs.
- ▶ **Enhanced CAPIF (eCAPIF).** R15 defines CAPIF to enable third parties to interface with the 3GPP network (e.g. LTE or 5G) in support of various applications, including edge applications. 3GPP is enhancing the original CAPIF by adding features such as support for multiple API providers, charging requirements, multiple deployment models and for both EPS and 5GS network exposure.
- ▶ **IMS.** 3GPP is enhancing the IMS network so that 5G capabilities such as network slicing can be exploited [16]. IMS modifications to the interface with the SBA of the 5GC are being investigated. Any IMS changes to support local traffic and associated service continuity are being studied. Support for URLLC such as a local instance of IMS as opposed to typical centralized IMS is also being explored.

- ▶ **Edge computing.** In R15, 3GPP defined support for edge computing where a UPF close to the UE could be selected for user traffic to derive benefits such as reduced end-to-end latency and reduced transport bandwidth requirements. 3GPP is exploring an architecture to enhance edge computing for a 3GPP network [14]. In this architecture, the UE has an edge application client and an edge enabler client. The edge data network, which would be close to the UE, has an edge application server and an edge enabler server. The core network also has an edge data network configuration server. The edge enabler server is responsible for the provisioning of configuration information to enable the exchange of application data traffic between the edge application client and the edge application server. The edge enabler server also conveys information about the edge application servers (e.g. availability of servers) to the edge enabler client. An edge data network configuration server provisions the edge data network configuration information in the edge enabler client. Such information includes service area information and information needed to establish a connection with an edge enabler server (e.g. uniform resource identifier). Deployment of edge computing apps requires communication between the 3GPP management system (e.g. OAM) and non-3GPP management systems such as ETSI multi-access edge computing (MEC) and ETSI NFV management and orchestration (MANO).
- ▶ **RAN slicing enhancements.** 3GPP defined network slicing in R15 to meet diverse customer requirements and widely different QoS requirements in a variety of verticals and industries. 3GPP is studying enhancements to RAN slicing in R17 so that network operators have more control of RAN resources to meet different customer requirements by customizing RAN design, deployment and operation. Network operators can benefit directly from the business success of their customers through customization rather than merely supporting over-the-top business practices. Generic slice template parameters may be studied. Mechanisms such as slice based cell reselection, sliced based random access, and slice based service continuity (e.g. slice remapping due to handover, fallback and data forwarding) may be considered.

5 MISCELLANEOUS ENHANCEMENTS

This section looks at auxiliary enhancements such as SEAL, SON and security.

5.1 SEAL

The service enabler architecture layer for verticals (SEAL) defines an application-level functional architecture to support a variety of verticals, including V2X and mission-critical services [13]. SEAL provides services such as group management, configuration management, location management, identity management, key management and network resource management. SEAL defines functional models for both application layer support aspects for verticals and the signaling control plane⁹⁾. For the application layer support, there are two functional models: on-network and off-network. The on-network model means that the UE is connected to the radio network via the Uu interface, and, the off-network model is applicable when a UE is using the PC5 interface. Fig. 5.1 illustrates the on-network model.

Fig. 5.1: SEAL on-network model for application layer support

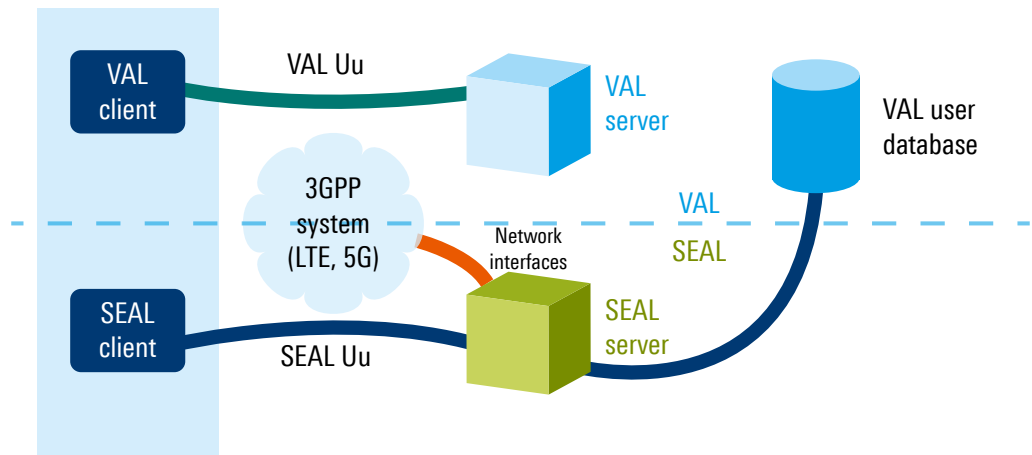

The UE has one or more vertical application layer (VAL) clients and one or more SEAL clients. Within the UE, VAL and SEAL clients use SEAL-C to communicate with each other. SEAL offers its services, such as group management and configuration management, to VAL. The UE communicates with VAL and SEAL servers using an LTE based or 5G based VAL Uu and SEAL Uu. The VAL Uu interface supports unicast and multicast delivery modes. VAL and SEAL servers communicate using SEAL-S. It is also possible for two SEAL servers to communicate with each other using SEAL-X. The SEAL server uses VAL-UDB with the VAL user database (which could be part of the home subscriber server) to store and retrieve user profiles. VAL clients and VAL servers are application-specific for a given vertical, while SEAL provides a common framework to multiple VAL applications.

In the off-network mode, VAL clients on two UEs use VAL-PC5 to communicate with each other, and SEAL clients on two UEs use SEAL-PC5 to communicate with each other. In this mode, one UE can act as a UE-to-network relay to enable suitable UEs to access VAL servers over VAL Uu.

VAL and SEAL services may be provided by PLMN operators or third parties.

⁹⁾ The signaling control plane involves the exchange of session initiation protocol (SIP) signaling between the UE and the SIP core. The SIP core could be IMS based or non IMS based. Such SIP signaling helps with SIP session management, subscriptions and authentication.

5.2 5G SON

A self-organizing network (SON) was defined earlier for LTE. SON includes self-configuration, self-optimization and self-healing. In addition, a given SON algorithm's deployment could be centralized, distributed or hybrid (i.e. a combination of centralized and distributed). A SON process is an open loop process when some human intervention exists. In the closed loop SON process, there is no human involvement (there can be exceptions). Fig. 5.2 shows examples of SON algorithms and use cases in 5G. 5G SON algorithms can be categorized as LTE-like algorithms and new 5G algorithms [17].

Fig. 5.2: 5G SON

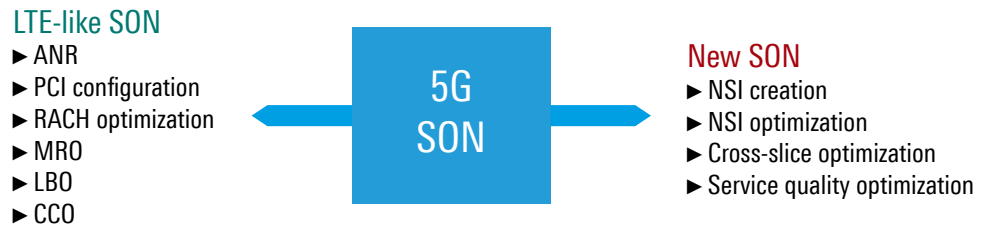

- ▶ **LTE-like SON algorithms.** Since LTE and 5G share several similarities, many SON algorithms defined for LTE can be applied to 5G. Examples of LTE-like algorithms that can be extended to 5G include automatic neighbor relation (ANR), physical cell identifier (PCI) configuration, random access channel (RACH) optimization, mobility robustness optimization (MRO), load balancing optimization (LBO) and capacity and coverage optimization (CCO). ANR enables the automatic creation of a neighbor list for a given cell to facilitate handover decision-making and UE measurement configuration. PCI configuration aims to address PCI related issues such as PCI collision (two neighbors with the same PCI) and PCI confusion (a cell with two neighbors using the same PCI). RACH optimization, as the name suggests, optimizes RACH parameters to improve the accessibility performance for RACH. MRO adjusts handover parameters to address issues such as early handover, late handover and handover to an incorrect cell. LBO redistributes users among cells by adjusting cell selection and handover parameters. CCO observes capacity and coverage metrics and adjusts the network configuration and operational parameters to enhance capacity and coverage.
- ▶ **New SON algorithms.** Network slicing is a new concept defined in 5G, so several SON algorithms related to network slicing are new algorithms in 5G. Examples of new 5G SON algorithms include automatic network slice instance (NSI) creation, NSI resource allocation optimization, cross-slice network resource optimization and service quality optimization. Automatic NSI creation enables the network operator to create a set of NSIs on demand based on customer requirements, which involves instantiation and configuration of NFs and connectivity among the NFs. NSI resource allocation optimization observes NSI performance data such as the number of registered UEs and protocol data unit (PDU) sessions and QoS measures to identify traffic patterns, predict the demand for network resources and optimize the allocation of network resources. Cross-slice network resource optimization aims to optimize the allocation of virtual and physical resources for NG-RAN and NGC across NSIs. Service quality optimization involves observing performance data for a given service (e.g. average latency for URLLC) and adjusting relevant configuration and operational parameters in the NG-RAN and NGC NFs.

R17 would address any unresolved SON features from R16. To support SON and minimization of drive tests (MDT), data collection mechanisms would be enhanced. For example, UE reporting to enhance network configuration and support new use cases (e.g. 2-step RACH optimization) may be specified. Both logged MDT (i.e. a UE report sent much later than the time of measurements) and immediate MDT (i.e. a UE

report sent soon after UE measurements) would be enhanced. MDT for multi-radio access technology dual connectivity (MR-DC) (i.e. UE simultaneously connected to two RATs such as NR and LTE) would be specified. Any new Layer 2 (L2) measurements, if required, may be introduced.

5.3 Security enhancements

In developing 5G, security has been a top concern from the start. R15 set the security framework [25], and R16 has followed up with many details, addressing many identified weaknesses in the framework. Security for 5G is particularly challenging because it is highly complex and extremely adaptable to support a wide variety of services that have conflicting requirements [26]. For instance, for URLLC applications low latency is of ultimate performance concern, yet it takes processing time to provide robust authentication and encryption. This means security must be optimized and appropriate for the specific 5G application. Optimization of the 5G system performance requires optimizing across various layers of the system, which means security must also be optimized across all the layers. Security must be designed as a chain; it is only as good as its weakest link and therefore 5G security design should aim for end-to-end assurance of security. This is particularly challenging since a 5G system may consist of equipment, software, transport links, services and systems from various entities.

Within 5G R16, numerous issues are being addressed, including:

- ▶ Security mechanism to prevent access to other network slices
- ▶ Trusted non-3GPP access
- ▶ Authentication of the user with security credentials
- ▶ Security for small data mode
- ▶ User plane DoS attacks
- ▶ Broadcast/multicast security
- ▶ Lawful intercept
- ▶ Battery sensitive security
- ▶ Location services security
- ▶ Edge device security
- ▶ Session management security
- ▶ Base station security test cases
- ▶ Security against false base stations
- ▶ Mission-critical architecture security

In addition, R16 has numerous ongoing studies that, if not integrated into R16, may be incorporated into future releases. These studies include:

- ▶ Relay security
- ▶ Security and connectivity from 5G to local area networks (may be studied in R17)
- ▶ Voice continuity
- ▶ Convergence of wireless and wireline systems
- ▶ Enhanced URLLC security
- ▶ Restrictions on local operators
- ▶ Enhanced virtualization security

One of the more attractive features of 5G is the ability to customize security and authentication with network slicing. But this feature does open up a number of different attack surfaces with SDN and NFV. Many vulnerabilities will still need to be addressed in future releases. Potential security vulnerabilities of 5G at various security layers have been identified in [28]. There is no doubt that security issues will continue to be addressed with each 3GPP release.

6 6G: A CRYSTAL BALL PERSPECTIVE

“Prediction is very difficult, especially if it’s about the future.” Niels Bohr, Nobel Laureate in Physics

“The best qualification of a prophet is to have a good memory.” Marquis of Halifax

If LTE stands for long term evolution, 5G is longer term evolution. However, it is a good idea to explore what the future may hold for 6G.

6.1 Predicting the 6G future

Predicting the future can be a futile task, but we all do it – we must in order to get ready for the future. Predicting the next generation of wireless technology is a favorite pastime for wireless engineers. Perhaps it is easier to do for the wireless field than for most fields since it is possible to look at the activities of standards bodies to gain insight into what vendors and service providers are trying to accomplish (and what they need to fix from the last standard). Even before the technology is debated in standards bodies, researchers are developing new ideas that can clearly provide improvements in performance over current systems.

History has taught us lessons that come from observing standards over the past five generations. For example,

1. Not all features spelled out in a given release of the standard are implemented immediately or simultaneously; rather, it could take some time for features to become practical. Likely this will be even more true for 5G given the unprecedented enormous scope of 5G technologies.
2. Weaknesses in the current standard become technology drivers for the next generation standard. This process has been especially true with privacy and security weaknesses.
3. We may be able to predict technology trends, but we are less successful in predicting business models that leverage those technology developments.
4. Sometimes new technologies may work great in simulations or prototypes used to create the standard. However, scaling from the lab models to commercial production and deployment does not always work so well and may take much longer than expected. Antenna arrays are a prime example.
5. New generations of wireless cellular standards tend to come in approximately 10-year increments. For example, LTE deployments started around 2008 and 5G was standardized in 2018.
6. The scope of the problems that wireless addresses increases with each generation. For example, 1st generation started with voice, 2nd generation enabled rudimentary connections to machines such as vending machines, 3rd generation enabled high-speed internet access including enhanced web browsing, and 4th generation made video entertainment over wireless practical. A greatly expanding application scope of 5th generation standards is widely anticipated.

7. New technologies adopted in standards may have much more impact than expected because of the development of synergistic technologies that together create a much more powerful effect. The development of high rate data transmission along with the improvement of display technology drove data demand even higher because it enabled mobile video entertainment.
8. In general, it takes longer to roll out all the capabilities of a standard than the initial hype might imply, but in the end the standard exceeds overall expectations.

These have been fairly consistent trends across all five generations of standards. What is new for the 6th generation of standards is that nations now recognize the importance of wireless standards for national economic well-being and national security. As a result, creating the fundamental technologies behind 6G has become much more competitive [29].

6.2 Key technologies as 6G enablers

One of the ways to predict what 6G may provide is to examine the direction of current fundamental and applied research. Three key enabling technologies are poised to drive the development of 6G: artificial intelligence (AI), advanced RF and optical technologies, and network technologies.

6.2.1 Artificial intelligence

No one would doubt that AI has become one of the most studied areas across many engineering disciplines. While 5G is known for a revolution in flexibility, 6G will likely be known for using AI to capitalize on flexibility [30]. In the past, wireless research activities have made use of AI in various areas, such as the design of handover algorithms using neural networks and fuzzy logic [31]. However, practical implementations of AI based algorithms in wireless networks have been relatively rare. The situation is changing now. Recent advances in learning techniques such as deep learning and new computing architectures that can make these complex algorithms practical have been key drivers behind this trend. Wireless communications is no exception to this trend. Fig. 6.1 shows what a 6G network could look like, with AI/cognition spread across all levels and optimized jointly across the levels in the radio access network, the core network and applications. Such adaptability can improve the resilience of the network and lower operational costs and maintenance costs.

Fig. 6.1: AI-driven 6G network

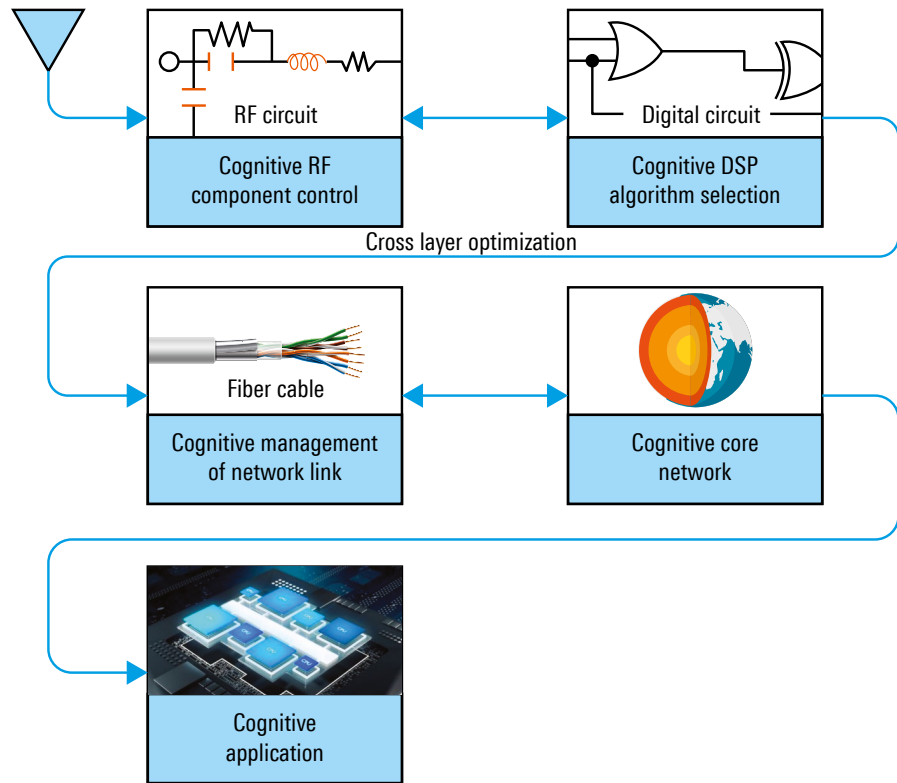

RF can benefit from cognitive tuning of components to optimize for environmental impairments (such as interference) or the impact of aging or detuning of the circuitry. Modems and protocols can be adaptive to facilitate better spectrum management and demodulation, especially in the case of heterogeneous interference, something to be expected with the emergence of spectrum sharing. Federated learning techniques can leverage each mobile unit as a sensor to provide a holistic yet detailed view of the interference and coverage issues across a broad region [32]. Mechanisms for supporting fronthaul and backhaul can be made more robust by using AI to find the appropriate mechanism for routing information, including the use of satellite or terrestrial wireless relaying. Studies are underway to examine the use of AI within the core network for system optimization, orchestration and maintenance [33]. Security of this overall AI-RAN can be continuously improved through the use of adversarial learning – competition between an AI network attacker and an AI network defender to find vulnerabilities and their solutions [34]. At the application level, AI can anticipate the context and need for application information and preset the network parameters to accommodate the anticipated information flow. (A form of “precognition”, a term from the science fiction movie Minority Report.)

6.2.2 RF and optical technologies

One of the key enablers of 5G has been the low-cost production of mmWave devices in recent times (in addition to the huge amount of spectrum available in the mmWave frequency bands). This trend is expected to continue, with higher frequency, more power efficient devices. Eventually, this technology trend may make terahertz (THz) communications economically feasible¹⁰⁾. A complete phased array can be placed on a chip [35]. Such a phased array chip would not need external power pins to communicate if wireless power is used.

Another factor is flexibility in RF components. The DARPA HEDGEHOG program is an example of such technology that is built on an RF field programmable gate array (FPGA) to create a very small radio that is highly configurable to cover a variety of bands from 10 MHz to 40 GHz – see Fig. 6.2 [36].

Fig. 6.2: Configurable RF: specs of Hedgehog (experimental DARPA radio)

Parameter	Specification
Frequency range	DC to 40 GHz
IBW	10 MHz to 2 GHz
Channels	8 TX, 8 RX
Integrated processing	<ul style="list-style-type: none"> ▶ GPP and FPGA ▶ over 280 Gbps I/O
Converters	<ul style="list-style-type: none"> ▶ 16 × 14-bit DACs ▶ 16 × 12-bit DACs ▶ integrated with processor

Covering all the Gs

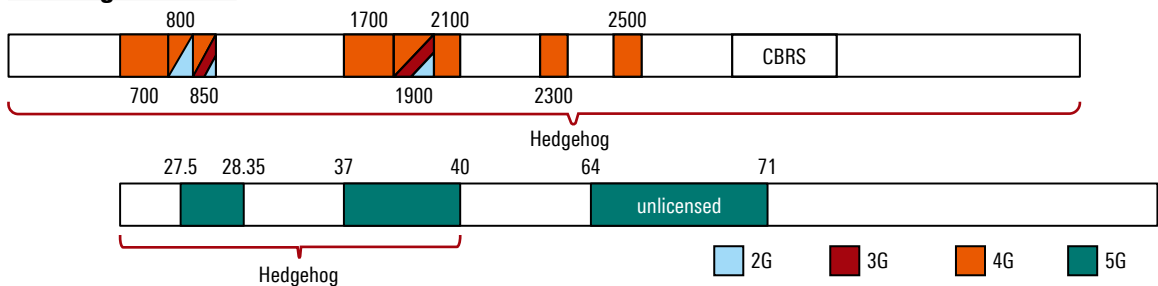

Such flexibility will work synergistically with AI to adapt the radio for the users' service needs and the RF environment. Taking full advantage of such technology requires the development of new communication protocols.

Single-frequency full-duplex has been demonstrated and is a testimony to ever-improving RF technology [38]. In such a system, the transmitter and receiver operate at the same time and on the same frequency, conceptually doubling the spectral efficiency of a system by eliminating the need for frequency or time duplexing. Such systems work by performing interference cancellation at the RF stage to remove the high-power transmit signal. Such technology will provide an even more flexible spectrum management technique for the 6th generation of wireless communications.

6G will no doubt extend beyond 95 GHz into the high mmWave and terahertz range, including the optical spectrum. At such frequencies, communications tend to be short range, but the devices can be tiny to support technologies such as ultra-massive MIMO and applications such as small swarms (insect-sized collaborating robots).

¹⁰⁾ The FCC has made THz spectrum in the 95 GHz to 3 THz range available for experimentation as part of the Spectrum Horizons order [37].

Optical 6G also shows promise with reduced interference, tremendous bandwidths, privacy to line-of-sight and an established technology base of devices that transmit and receive. Interestingly, ultraviolet light does NOT require line of sight; it scatters in the atmosphere¹¹⁾.

6.2.3 Network technologies

Like 5G, network technologies for 6G will continue the use of SDN, NFV and network slicing. However, 6G could take these concepts to the extreme, allowing customized network slices according to an individual's needs and applications to create a truly customized quality of experience for that individual. Such a system with personalized network slices would inevitably leverage edge computing on a massive scale and create a very complex distribution of network responsibilities between the core network and edge computing nodes.

6.3 Potential performance targets for 6G

New standards have a variety of metrics that include typical specifications of data rates, latency and availability. 6G will continue with the trend begun with 5G of defining quality of experience (QoE) over individual metrics. Certainly, there will be higher data rates, perhaps terabits per second. Latencies may be as low as tens of microseconds, and perhaps information will be freshness dated with the age-of-information to aid in prioritized processing of information. Power consumption reductions that are already targeted for 10 year battery life for IoT devices in 5G could be further reduced to allow energy harvesting, including backscatter communications [39]. 6G might also include both metrics and standards for energy harvesting and wireless power requirements. One might expect to see metrics for security resilience in 6G standards, especially with the potential of quantum computing to be able to break most encryption standards by the time 6G appears.

6.4 Potential 6G services

So what sort of services might 6G and beyond wireless systems provide? 6G will build on 5G to enhance existing services as well as introduce additional modes to handle applications with widely different needs [40]. For example, while 5G will introduce holograms, 6G would likely enable high-fidelity holograms on a massive scale. One possible new application area is providing ultra-low-power communications to tiny devices through energy harvesting or wireless power. Such devices could be part of the fabric of clothes or embedded into plastic or glass. They could constitute the communications between swarms of small UAVs or robots that can coordinate to perform complex tasks such as assembly and repairs. There may eventually be many thousands of radios per individual. Accomplishing this would require a standard with protocols that facilitate energy transfer (wireless power) or energy harvesting configuration merged with communications protocols.

We could see new applications that require a whole new level of latency management. For example, low enough latency for precise power grid control with distributed energy sources and sinks. Tactile sensing applications also push the limits for low latency. This could be accomplished with freshness dating information using an age-of-information metric to prioritize processing or it could be achieved by using AI to anticipate communications or application needs or potential faults to provide robust connectivity. Such capability will allow imperceptible seamless coverage, including a rapid transition between satellite communications and terrestrial communications.

¹¹⁾ In the late 1990s, an infrared version existed in the early 802.11 specification to provide up to 2 Mbps connectivity. It could be found on selected laptops at that time.

Services that require data rates even higher than ultra high are inevitable. One possible service may be video wallpaper that uses large display technology to form the walls of a room with projected images. We are now seeing the emergence of 8k video, and data speeds to support 8k video are around 360 Mbps. Scaling this up to provide an immersive experience on each wall means that one wall may need well over 10 Gbps of communications speed for a real-time display. In this case, a terabit per second link is not an unreasonable need.

Sensing as a service is a possible new category for 6G applications. Could 6G signals be used to measure moisture or other particulates in the air to create a micro-climate profile? Could it be possible to leverage the signal as a radar signal to get very precise localization for indoor flying UAVs?

It is difficult to say at this point what 6G may bring. While an initial version of 6G might come in the 2030 time range, it will also undergo several years of revisions. Predicting what the standard will evolve to in 2035 is a fascinating but very speculative endeavor.

7 SUMMARY

5G Phase 1 or R15 provides a strong foundation for enhancements in future releases by defining a high performance NR air interface and flexible network architecture. R16 and later releases focus on new verticals to significantly expand the applications of wireless communications. This trend to support verticals is expected to accelerate in 6G.

Going beyond the eMBB-centric R15, R16 and later releases will expand the supported services. 5G LAN can replace or augment fixed or wireless LAN and provide flexibility and enhanced performance. In non-terrestrial networks, satellites use 5G to provide service ubiquity, service continuity and service scalability. Critical medical applications benefit from 5G performance to improve healthcare and reduce costs. 5G enables new V2X use cases such as platooning, advanced driving and remote driving. 5G based UAVs can support a variety of scenarios including delivery of medical supplies in disaster situations. 5G facilitates audio-visual production services inside and outside studios. Cyber-physical control applications can exploit 5G to make Industry 4.0 a reality on a large scale. NR based positioning supports numerous use cases, including emergency situations, UAV operations, AR/VR/XR and factory automation. Haptic communication takes the user experience to a whole new level by exploiting the haptic sense.

NR undergoes numerous enhancements beyond R16. NR-U uses NR in unlicensed spectrum and supports a variety of scenarios, including carrier aggregation and dual connectivity. IAB enables the use of spectrum for backhaul in addition to traditional access to reduce deployment costs and simplify radio-core connectivity. URLLC-centric enhancements include increased reliability, faster processing, more flexible HARQ, uplink cancellation and enhanced uplink power control. Industrial IoT related NR enhancements include support for TSN reference times and Ethernet, flexible grants and scheduling. New frequency bands between 7 GHz and 24 GHz and above 53 GHz open up more spectrum for numerous use cases, including densification, industrial IoT, backhaul, fronthaul and ITS. NR also makes enhancements related to MIMO, mobility, positioning and UE power savings.

R15 defines virtualization-friendly service based architecture. This architecture is enhanced for V2X, network automation, CLI/RIM, eCAPIF and IMS. V2X related enhancements include support for the NR based PC5 interface. NWDAF and its interactions with other NFs are being expanded to increase the degree of automation and to facilitate AI based operations. The work on CLI/RIM aims to enable dynamic TDD while reducing overall interference. eCAPIF supports multiple API providers and addresses charging requirements. IMS is being enhanced to work with SBA and to support edge computing.

3GPP is also defining SEAL and SON for 5G and enhancing the security framework. At the application layer, SEAL provides services such as group management and configuration management to applications of various verticals by working with the vertical application layer (VAL). 5G SON supports traditional LTE-like algorithms such as ANR and PCI configuration along with new algorithms related to network slicing. Security is being further tightened, especially in light of the expansion into new verticals.

While R16 and later releases for 5G have immense untapped potential, 6G will take the user experience to a whole new level and would revolutionize many industries. Data rates on the order of terabits per second, latency on the order of few microseconds, and high energy efficiencies for the devices and the network could be hallmarks of 6G. High-fidelity holographic communications and multisensory communications could become part of our daily lives. While industries such as healthcare, manufacturing, entertainment and transportation would begin to be influenced by 5G, they would be transformed on a larger scale by 6G.

The world around us will be significantly shaped by the upcoming enhancements in wireless communications. Be prepared to be amazed.

8 LITERATURE

- [1] Nishith D. Tripathi and Jeffrey H. Reed, "5G Cellular Communications - Journey and Destination", multimedia eBook, <https://thewirelessuniversity.com/>, May 2019
- [2] Rohde & Schwarz, "5G New Radio", <https://www.mobilewirelesstesting.com/5g-new-radio-digital-book/>, 2019
- [3] 3GPP, TS 22.104, "Service requirements for cyber-physical control applications in vertical domains; Stage 1", <https://portal.3gpp.org/desktopmodules/Specifications/SpecificationDetails.aspx?specificationId=3528>
- [4] 3GPP, TR 22.821, "Feasibility Study on LAN Support in 5G", <https://portal.3gpp.org/desktopmodules/Specifications/SpecificationDetails.aspx?specificationId=3281>
- [5] 3GPP, TR 22.822, "Study on using satellite access in 5G", <https://portal.3gpp.org/desktopmodules/Specifications/SpecificationDetails.aspx?specificationId=3372>
- [6] 3GPP, TR 22.826, "Study on communication services for critical medical applications", <https://portal.3gpp.org/desktopmodules/Specifications/SpecificationDetails.aspx?specificationId=3546>
- [7] 3GPP, TR 22.827, "Study on Audio-Visual Service Production", <https://portal.3gpp.org/desktopmodules/Specifications/SpecificationDetails.aspx?specificationId=3520>
- [8] 3GPP, TR 22.829, "Enhancement for Unmanned Aerial Vehicles (UAVs)", <https://portal.3gpp.org/desktopmodules/Specifications/SpecificationDetails.aspx?specificationId=3557>
- [9] 3GPP, TR 22.832, "Study on enhancements for cyber-physical control applications in vertical domains", <https://portal.3gpp.org/desktopmodules/Specifications/SpecificationDetails.aspx?specificationId=3629>
- [10] 3GPP, TR 22.872, "Study on positioning use cases", <https://portal.3gpp.org/desktopmodules/Specifications/SpecificationDetails.aspx?specificationId=3280>
- [11] 3GPP, TR 22.886, "Study on enhancement of 3GPP support for 5G V2X services", <https://portal.3gpp.org/desktopmodules/Specifications/SpecificationDetails.aspx?specificationId=3108>
- [12] 3GPP, TS 23.287, "Architecture enhancements for 5G System (5GS) to support Vehicle-to-Everything (V2X) services", <https://portal.3gpp.org/desktopmodules/Specifications/SpecificationDetails.aspx?specificationId=3578>
- [13] 3GPP, TS 23.434, "Service Enabler Architecture Layer for Verticals (SEAL); Functional architecture and information flows", <https://portal.3gpp.org/desktopmodules/Specifications/SpecificationDetails.aspx?specificationId=3587>
- [14] 3GPP, TR 23.758, "Study on Application Architecture for enabling Edge Applications", <https://portal.3gpp.org/desktopmodules/Specifications/SpecificationDetails.aspx?specificationId=3614>
- [15] 3GPP, TR 23.791, "Study of enablers for Network Automation for 5G", <https://portal.3gpp.org/desktopmodules/Specifications/SpecificationDetails.aspx?specificationId=3252>
- [16] 3GPP, TR 23.794, "Study on Enhanced IMS to 5GC Integration", <https://portal.3gpp.org/desktopmodules/Specifications/SpecificationDetails.aspx?specificationId=3421>
- [17] 3GPP, TR 28.861, "Telecommunication management; Study on the Self-Organizing Networks (SON) for 5G networks", <https://portal.3gpp.org/desktopmodules/Specifications/SpecificationDetails.aspx?specificationId=3556>

- [18] 3GPP, TR38.824, “Study on physical layer enhancements for NR ultra-reliable and low latency case (URLLC)”, <https://portal.3gpp.org/desktopmodules/Specifications/SpecificationDetails.aspx?specificationId=3498>
- [19] 3GPP, TR38.825, “Study on NR industrial Internet of Things (IoT)”, <https://portal.3gpp.org/desktopmodules/Specifications/SpecificationDetails.aspx?specificationId=3492>
- [20] 3GPP, TR38.840, “Study on User Equipment (UE) power saving in NR”, <https://portal.3gpp.org/desktopmodules/Specifications/SpecificationDetails.aspx?specificationId=3502>
- [21] 3GPP, TR38.855, “Study on NR positioning support”, <https://portal.3gpp.org/desktopmodules/Specifications/SpecificationDetails.aspx?specificationId=3501>
- [22] 3GPP, TR38.874, “Study on integrated access and backhaul”, <https://portal.3gpp.org/desktopmodules/Specifications/SpecificationDetails.aspx?specificationId=3232>
- [23] 3GPP, TR38.889, “Study on NR-based access to unlicensed spectrum”, <https://portal.3gpp.org/desktopmodules/Specifications/SpecificationDetails.aspx?specificationId=3235>
- [24] 3GPP, RP-182863, “Revised WID: Enhancements on MIMO for NR”, <https://portal.3gpp.org/ngppapp/CreateTdoc.aspx?mode=view&contributionUid=RP-182863>
- [25] 3GPP TS 33.501, “Security architecture and procedures for 5G system (Release 15)”, <https://portal.3gpp.org/desktopmodules/Specifications/SpecificationDetails.aspx?specificationId=3169>
- [26] 5G Americas, “The Evolution of Security in 5G: A “Slice” of Mobile Threats, July 2019”, white paper, https://www.5gamericas.org/wp-content/uploads/2019/08/5G-Security-White-Paper_8.15.pdf
- [27] 3GPP, specification series for security issues, <https://www.3gpp.org/DynaReport/33-series.htm>
- [28] UK5G, “Technical Report on 5G Network Architecture and Security”, A collaborative paper, DCMS Phase 1 5G Testbeds&Trials Programme, UK5G Report, December 2018, <https://uk5g.org/5g-updates/research/technical-report-5g-network-architecture-and-securl/>.
- [29] Martijn Rasser, “Setting the Stage for U.S. Leadership in 6G”, August 13, 2019, LawFare, <https://www.lawfareblog.com/setting-stage-us-leadership-6g>
- [30] M. Yao, M. Sohal, V. Marojevic, J.H. Reed, “Artificial Intelligence0Defined 5G Radio Access Networks”, IEEE Communications Magazine, Volume 57 Issue 3, March 2019, pages 14-20. doi>10.1109/MCOM.2019.1800629
- [31] Nishith D. Tripathi, Jeffrey H. Reed, and Hugh F. VanLandingham, “Radio Resource Management in Cellular Systems”, Kluwer Academic Publishers, 2002
- [32] Solmaz Niknam, Harpreet S. Dhillon, Jeffery H. Reed, Federated Learning for Wireless Communications: Motivation, Opportunities and Challenges, <https://arxiv.org/abs/1908.06847>, (Submitted on 30 Jul 2019 (v1), last revised 24 Aug 2019 (this version, v2))
- [33] Improved operator experience through Experiential Networked Intelligence (ENI) Introduction – Benefits – Enablers – Challenges – Call for Action, ETSI White Paper No. 22, 1st Edition, October 2017, ISBN No. 979-10-92620-16-0. https://www.etsi.org/images/files/ETSIWhitePapers/etsi_wp22_ENI_FINAL.pdf
- [34] Y. Shi, Y. E. Sagduyu, T. Erpek, K. Davaslioglu, Z. Lu and J. H. Li, “Adversarial Deep Learning for Cognitive Radio Security: Jamming Attack and Defense Strategies”, 2018 IEEE International Conference on Communications Workshops (ICC Workshops), Kansas City, MO, 2018, pp. 1-6. doi: 10.1109/ICCW.2018.8403655Satcomm

- [35] M. M. Assefzadeh and A. Babakhani, "Broadband beamforming of terahertz pulses with a single-chip 4x2 array in silicon", 2016 IEEE International Symposium on Antennas and Propagation (APSURSI), Fajardo, 2016, pp. 589-590. doi: 10.1109/APS.2016.7696003
- [36] Tom Rondeau, "RF Convergence: From the Signals to the Computer", IEEE Workshop on 5G Technologies for Tactical and First Responder Networks Columbia, MD, 10/23/2018
- [37] FCC 19-19, "Spectrum Horizons First Report and Order", ET Docket No. 18-21, <https://www.fcc.gov/document/fcc-opens-spectrum-horizons-new-services-technologies-0>
- [38] C. D. Nwankwo, L. Zhang, A. Quddus, M. A. Imran and R. Tafazolli, "A Survey of Self-Interference Management Techniques for Single Frequency Full Duplex Systems", in IEEE Access, vol. 6, pp. 30242-30268, 2018. doi: 10.1109/ACCESS.2017.2774143
- [39] N. Van Huynh, D. T. Hoang, X. Lu, D. Niyato, P. Wang and D. I. Kim, "Ambient Backscatter Communications: A Contemporary Survey", in IEEE Communications Surveys & Tutorials, vol. 20, no. 4, pp. 2889-2922, Fourth quarter 2018. doi: 10.1109/COMST.2018.2841964
- [40] P. Yang, Y. Xiao, M. Xiao and S. Li, "6G Wireless Communications: Vision and Potential Techniques", in IEEE Network, vol. 33, no. 4, pp. 70-75, July/August 2019. doi: 10.1109/MNET.2019.1800418
- [41] 3GPP, TR38.305, "Stage 2 functional specification of User Equipment (UE) positioning in NG-RAN", <https://portal.3gpp.org/desktopmodules/Specifications/SpecificationDetails.aspx?specificationId=3310>

Rohde & Schwarz

The Rohde & Schwarz electronics group offers innovative solutions in the following business fields: test and measurement, broadcast and media, secure communications, cybersecurity, monitoring and network testing. Founded more than 80 years ago, the independent company which is headquartered in Munich, Germany, has an extensive sales and service network with locations in more than 70 countries.

www.rohde-schwarz.com

Rohde & Schwarz customer support

www.rohde-schwarz.com/support

